

XP-1A/B 系列精密减速机

XP-1A/B SERIES PRECISION PLANETARY GEARBOX

产品图 Product Graph

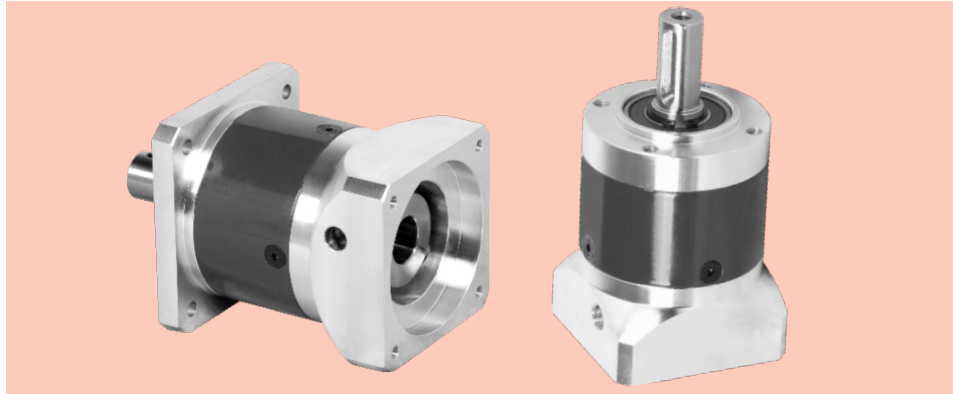

技术资料 Technical Data

产品型号 Product type		40	60	80	120	160	减速比 Reduction ratio	级数 Number of stage
额定输出扭矩 Rated output torque	N.M	4.5	12	40	80	400	3	1
		6	16	50	110	450	4	
		6	16	50	110	450	5	
		5	15	45	100	400	8	
		4	12	40	80	305	10	
		/	40	100	210	/	9	
		16.5	40	100	210	700	12	2
		16.5	40	100	210	700	15	
		20	44	120	260	800	16	
		20	44	120	260	800	20	
		18	40	110	230	700	25	
		20	44	120	260	800	32	
		18	40	110	230	700	40	
		7.5	18	45	100	400	64	
		16.5	40	100	210	/	60	3
		20	44	120	260	/	80	
		20	44	120	260	/	100	
		16.5	40	100	210	/	120	
		20	44	120	260	/	160	
		18	40	110	230	/	200	
20	44	120	260	/	256			
18	40	110	230	/	320			
7.5	18	45	100	/	512			
寿命 Life	小时 Hour	20,000						
瞬间急停扭矩 Instant stop torque	N.M	2倍于额定输出扭矩 Two times of rated output torque						
产品型号 Product type		40	60	80	120	160	单位 Unit	级数 Number of stage
最大径向力 Max radial torque		160	450	900	2100	6000	N	
最大轴向力 Max axial torque		80	225	450	1050	3000	N	
满载效率 Full load efficiency		96					%	1
		94						2
		90						3
重量 Weight		0.4	0.9	2.1	6	18	Kg	1
		0.5	1.1	2.6	8	22		2
		0.6	1.3	3.1	9.5	/		3
工作温度 Operating temperature		-25~+90					°C	
保护等级 IP		IP54						
润滑方式 Lubrication type		终身润滑 Lifetime lubrication						
安装方式 Mounting type		任意 Any						

最大径向力与最大轴向力,输出100RPM时,作用于输出轴中心位置(L/2)处。

The max radial and axial torque work in the location of the center of output shaft when the out speed is 100RPM.

XP-1A/B 系列精密减速机

XP-1A/B SERIES PRECISION PLANETARY GEARBOX

技术资料 Technical Data

产品型号 Product type		40	60	80	120	160	减速比 Reduction ratio
转动惯量 Moment of inertia	Kgcm ²	0.031	0.135	0.77	2.63	12.14	3
		0.022	0.093	0.52	1.79	7.78	4
		0.019	0.078	0.45	1.53	6.07	5
		0.017	0.065	0.39	1.32	4.63	8
		0.015	0.054	0.34	1.14	3.52	10
		/	0.131	0.74	2.62	/	9
		0.022	0.088	0.50	2.56	7.47	12
		0.019	0.077	0.44	1.79	6.65	15
		0.022	0.088	0.50	1.75	7.47	16
		0.019	0.075	0.44	1.50	6.65	20
		0.019	0.075	0.44	1.49	5.81	25
		0.017	0.064	0.39	1.30	4.50	32
		0.016	0.064	0.39	1.30	4.50	40
		0.016	0.064	0.39	1.30	4.50	64
		0.019	0.075	0.50	1.50	/	60
		0.019	0.075	0.50	1.50	/	80
		0.019	0.075	0.44	1.49	/	100
		0.016	0.064	0.39	1.30	/	120
0.016	0.064	0.39	1.30	/	160		
0.016	0.064	0.39	1.30	/	200		
0.016	0.064	0.39	1.30	/	256		
0.016	0.064	0.39	1.30	/	320		
0.016	0.064	0.39	1.30	/	512		

产品型号 Product type		40	60	80	120	160	级数 Number of stage
回程间隙 Backlash	arcmin 弧分	< 12	< 8	< 8	< 8	< 8	1
		< 15	< 12	< 12	< 12	< 12	2
		< 18	< 15	< 15	< 15	/	3

产品型号 Product type		40	60	80	120	160	
抗扭刚性 Torsional stiffness	N.M/arcmin	0.7	1.8	4.5	12	38	
噪声 Noise	dB(A)	55	58	60	65	70	
最高输入转速 Max input speed	min ⁻¹	4500	4500	4500	4500	4500	
推荐输入转速 Recommnd input speed	min ⁻¹	3000	3000	3000	3000	3000	

- 转动惯量与输入轴有关。The moment of inertia is related with input shaft.
- 噪声检测标准，距离1m，在输入转速3000转/分空载时测得。Noise test standard pressure level, distance 1m, measured on idle running with an input speed of 3000rpm.

XP-1A 系列精密减速机

XP-1A SERIES PRECISION PLANETARY GEARBOX

机械参数 Dimensions

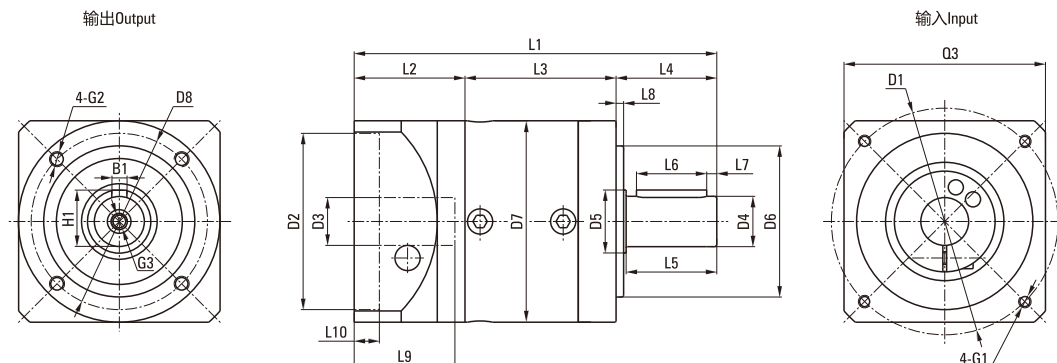

单位 Unit: mm

产品型号 Product type	40ZDE			60ZDE			80ZDE			120ZDE			160ZDE	
级数 Number of stage	1	2	3	1	2	3	1	2	3	1	2	3	1	2
L1箱体总长 L1 overall length	93.5	106.5	119	114	127	140	144	162	179.5	195.2	223	250.5	302	340.5
L3箱体长度 L3 body length	39	52	64.5	46.5	59.5	72.5	60	78	95.5	73.7	101.5	129	116	153.5
输出端 Output														
L4出轴长度 L4 output shaft length	26			35			40			55			87	
L5出轴长至轴肩 L5 output length to the shaft shoulder	23			30.5			36			50			80	
L6键长度 L6 key length	16			25			28			40			70	
L7键至轴末端长 L7 key length to the shaft end	3.5			2.5			4			5			5	
L8定位凸台长度 L8 spigot length	2			3			3			4			5	
D4出轴直径 D4 output shaft diameter	Φ10h7			Φ14h7			Φ20h7			Φ25h7			Φ40h7	
D5轴肩直径 D5 shaft shoulder diameter	Φ12			Φ17			Φ25			Φ35			Φ55	
D6定位凸台直径 D6 spigot diameter	Φ26h7			Φ40h7			Φ60h7			Φ80h7			Φ130h7	
D7箱体直径 D7 body diameter	Φ40			Φ60			Φ80			Φ115			Φ160	
D8安装孔分布圆 D8 hole circle	Φ34			Φ52			Φ70			Φ100			Φ145	
B1键宽 B1 key width	3			5			6			8			12	
H1键高 H1 key height	11.2			16			22.5			28			43	
G2安装螺孔 G2 mounting screw hole	M4X6			M5X8			M6X10			M10X16			M12X20	
G3中心螺孔 G3 center screw hole	M3X9			M5X12			M6X16			M10X22			M12X25	
输入端 Input														
L2输入法兰长度 L2 input flange length	28.5			32			44			66.5			99	
L9电机轴长度 L9 motor shaft length	26			30			40			58			79	
L10定位凸台深 L10 spigot depth	6			10			10			10			10	
D1安装孔分布圆 D1 mounting hole distribution circle	Φ46			Φ70			Φ90			Φ145			Φ200	
D2定位凸台直径 D2 spigot diameter	Φ30G7			Φ50G7			Φ70G7			Φ110G7			Φ114.3G7	
D3输入轴轴径 D3 input shaft diameter	≤Φ8G7			≤Φ14G7			≤Φ19G7			≤Φ24G7			≤Φ35G7	
G1安装螺孔x深度 G1 mounting threads x depth	M4X10			M5X12			M6X15			M8X22			M12X25	
Q3输入法兰 Q3 input flange	□40			□60			□80			□130			□175	

※输入端尺寸可根据电机尺寸制作。

※Input size made according to motor size.

XP-1B 系列精密减速机

XP-1B SERIES PRECISION PLANETARY GEARBOX

机械参数 Dimensions

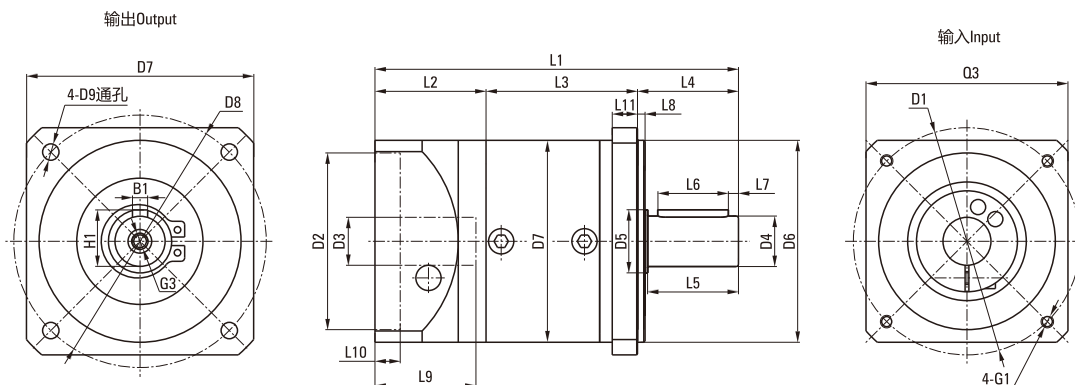

单位 Unit: mm

产品型号 Product type	40ZDF			60ZDF			80ZDF			120ZDF			160ZDF	
级数 Number of stage	1	2	3	1	2	3	1	2	3	1	2	3	1	2
L1箱体总长 L1 overall length	93.5	106.5	119	114	127	140	144	162	179.5	195.2	223	250.5	302	345.5
L3箱体长度 L3 body length	39	52	64.5	46.5	59.5	72.5	60	78	95.5	73.7	101.5	129	116	159.5
输出端 Output														
L4出轴长度 L4 output shaft length	26			35			40			55			87	
L5出轴长至轴肩 L5 output length to the shaft shoulder	23			30.5			36			50			80	
L6键长度 L6 key length	16			25			28			40			70	
L7键至轴末端长 L7 key length to the shaft end	3.5			2.5			4			5			5	
L8定位凸台长度 L8 spigot length	2			3			3			4			5	
L11输出法厚度 L11 output flange thickness	6			8			10			15			15	
D4出轴直径 D4 output shaft diameter	Φ10h7			Φ14h7			Φ20h7			Φ25h7			Φ40h7	
D5轴肩直径 D5 shaft shoulder diameter	Φ12			Φ17			Φ25			Φ35			Φ55	
D6定位凸台直径 D6 spigot diameter	Φ26h7			Φ50h7			Φ80h7			Φ110h7			Φ130h7	
D7输出法兰 D7 output flange	□45			□60			□90			□120			□160/□175	
D8安装孔分布圆 D8 hole circle	Φ50			Φ70			Φ100			Φ130			Φ185/Φ200	
D9法兰安装孔 D9 mounting hole	Φ3.5			Φ5.5			Φ6.5			Φ8.5			Φ11/Φ13.5	
B1键宽 B1 key width	3			5			6			8			12	
H1键高 H1 key height	11.2			16			22.5			28			43	
G3中心螺纹孔 G3 center screw hole	M3X9			M5X12			M6X16			M10X22			M12X25	
输入端 Input														
L2输入法兰长度 L2 input flange length	28.5			32			44			66.5			99	
L9电机轴长度 L9 motor shaft length	26			30			40			58			79	
L10定位凸台深 L10 spigot depth	6			10			10			10			10	
D1安装孔分布圆 D1 mounting hole distribution circle	Φ46			Φ70			Φ90			Φ145			Φ200	
D2定位凸台直径 D2 spigot diameter	Φ30G7			Φ50G7			Φ70G7			Φ110G7			Φ114.3G7	
D3输入轴轴径 D3 input shaft diameter	≤Φ8G7			≤Φ14G7			≤Φ19G7			≤Φ24G7			≤Φ35G7	
G1安装螺纹孔x深度 G1 mounting threads x depth	M4X10			M5X12			M6X15			M8X22			M12X25	
Q3输入法兰 Q3 input flange	□40			□60			□80			□130			□175	

※输入端尺寸可根据电机尺寸制作。

※Input size made according to motor size.